



IPIX<sup>®</sup> CommandView<sup>™</sup>  
Dome



CV-D2000

Installation Instructions

# SAFETY PRECAUTIONS



CAUTION: TO REDUCE THE RISK OF ELECTRICAL SHOCK, DO NOT OPEN COVERS. NO USER SERVICEABLE PARTS INSIDE. REFER SERVICING TO QUALIFIED SERVICE PERSONNEL.

This label may appear on the bottom of the unit due to space limitations.



The lightning flash with an arrowhead symbol within an equilateral triangle is intended to alert the user to the presence of uninsulated "dangerous voltage" within the product's enclosure that may be of sufficient magnitude to constitute a risk of electric shock to persons.



The exclamation point within an equilateral triangle is intended to alert the user to presence of important operating and maintenance (servicing) instructions in the literature accompanying the appliance.

WARNING: TO PREVENT FIRE OR SHOCK HAZARD, DO NOT EXPOSE INTERNAL COMPONENTS TO RAIN OR MOISTURE.



**Attention:** Installation should be performed by qualified service personnel only in accordance with the National Electrical Code or applicable local codes.

## For 24 VAC Installations:

Do Not Exceed 26.4 VAC Input. Voltage applied to the unit's power input should not exceed 26.4 VAC. Normal input voltage is 24 VAC. User supplied wiring from 24 VAC supply to unit must be in compliance with electrical codes (Class 2 power levels). Do not ground 24 VAC supply at power supply terminals or at unit's power supply terminals.

# SECURITE



**ATTENTION**

**RISQUE D'ÉLECTROCUTION.  
NE PAS OUVRIR**



DANGER: POUR ÉVITER TOUT RISQUE D'ÉLECTROCUTION, NE PAS OUVRIR LE BOÎTIER. IL N'Y A PAS DE PIÈCES REMPLAÇABLES À L'INTÉRIEUR. POUR TOUTE RÉVISION, S'ADRESSER À UN TECHNICIEN SPÉCIALISÉ.

En raison de limitation de place, cette étiquette peut être placée sur le dessous de l'appareil.



L'éclair fléché dans un triangle équilatéral, avertit l'utilisateur de la présence d'une "tension dangereuse" non isolée à l'intérieur de l'appareil et d'une valeur suffisante pour constituer un risque d'électrocution.



Le point d'exclamation contenu dans un triangle équilatéral, avertit l'utilisateur de la présence, dans la documentation qui accompagne l'appareil, de consignes d'utilisation et de maintenance importantes.

AVERTISSEMENT : RISQUE D'INCENDIE OU DE CHOCS ÉLECTRIQUES. NE PAS EXPOSER LES COMPOSANTS INTERNES À LA PLUIE NI À L'HUMIDITÉ.



**Attention:** L'installation doit être effectuée uniquement par du personnel de service qualifié conformément à la réglementation du Code Electrique National ou à la réglementation locale.

## Pour Installations à 24 V c.a. :

Ne pas excéder 26.4 VCA. La tension appliquée à l'entrée d'alimentation de l'appareil ne devrait pas excéder 26.4 VCA. Toute installation électrique fournissant du 24 Volts courant alternatif doit être conforme aux codes électriques. (Niveaux d'alimentation de la Classe 2). Ne pas brancher une prise de terre sur les bornes d'alimentation 24 Volts ou aux bornes d'alimentation de l'appareil.

# SICHERHEITSVORKEHRUNGEN



VORSICHT: UM EINEN ELEKTRISCHEN SCHLAG ZU VERMEIDEN, ABDECKUNG NICHT ENTFERNEN. WARTUNGEN ALLER ART QUALIFIZIERTEM PERSONAL ÜBERLASSEN.

Aus Platzgründen kann diese Warnung auf der Unterseite des Gerätes angebracht sein.



Das Blitzsymbol im gleichseitigen Dreieck soll den Benutzer auf nicht isolierte "Hochspannung" im Gehäuse aufmerksam machen, die eventuell stark genug ist, um einen elektrischen Schlag zu verursachen.



Das Ausrufezeichen im gleichseitigen Dreieck soll den Benutzer auf wichtige Bedienungs- und Wartungsanleitungen in der dem Gerät beigelegten Literatur aufmerksam machen.

WARNUNG: SCHÜTZEN SIE DIE INNEREN KOMPONENTEN VOR REGEN UND FEUCHTIGKEIT, UM BRÄNDE ODER ELEKTRISCHE SCHLÄGE ZU VERMEIDEN.



**Achtung!** Die Installation sollte nur von qualifiziertem Kundendienstpersonal gemäß jeweilig zutreffender Elektrovorschriften ausgeführt werden.

## FÜR INSTALLATIONEN BEI 24 V WECHSELSPANNUNG:

Achtung! 26.4 Volt Eingangswchselspannung darf für 26.4 VAC Modelle nicht überschritten werden. Normal-betrieb findet bei 24 Volt Wechselspannung statt. Die Kabel- bzw. Drahtverbindung vom Netzgerät zu dem vor-liegenden Gerät muß die Bestimmungen der Schutz-klasse II erfüllen. Nicht die 24-Volt-Leitung erden weder am Netzgerät noch an den Anschlußklemmen des vorlie-genden Gerätes.

# PRECAUCIONES DE SEGURIDAD



## PRECAUCION

RIESGO DE CHOQUE  
ELECTRICO. ¡NO ABRIR!



PRECAUCION: PARA REDUCIR EL RIESGO DE CHOQUE ELÉCTRICO, FAVOR NO ABRIR LA CUBIERTA. ESTE EQUIPO NO CONSTA DE PIEZAS O PARTES QUE REQUIEREN SERVICIO O MANTENIMIENTO. PARA REPARACIONES FAVOR REFERIRSE A UN TÉCNICO CALIFICADO.

Debido a limitaciones de espacio, esta etiqueta puede aparecer en la parte inferior de la unidad.



El símbolo representado por un relámpago con punta de flecha dentro de un triángulo equilátero, se muestra con el objetivo de alertar al usuario que existen "voltajes peligrosos" sin aislamiento, dentro de la cubierta de la unidad. Dichos voltajes pueden ser de tal magnitud que constituyen un riesgo de choque eléctrico a personas.



El símbolo de exclamación dentro de un triángulo equilátero, se muestra con el objetivo de alertar al usuario de que instrucciones de operación y mantenimiento importantes acompañan al equipo.

ADVERTENCIA: PARA EVITAR RIESGOS DE INCENDIOS O DESCARGAS ELÉCTRICAS, NO EXPONGA LOS COMPONENTES INTERNOS A LLUVIA NI A HUMEDAD.



**Atención:** La instalación de este equipo debe ser realizada por personal capacitado, solo en acuerdo, y en cumplimiento de normas del "National Electric Code" (Código Eléctrico Nacional) ó las normas del Gobierno Nacional Local.

### Para instalaciones de 24 V (CA):

No exceder 26.4 VCA de entrada. Voltage suplido a la unidad no debe exceder 26.4 VCA. Voltage de entrada normal es de 24 VCA. El cableado de 24 VCA provisto por el usuario debe cumplir con las normas eléctricas (Clase 2 de niveles de alimentación). No conectar los 24 VCA a tierra en las terminales de la alimentación ó a las terminales de la fuente de alimentación de la unidad.

## FCC & ICES INFORMATION

(U.S.A. and Canadian Models Only)

**WARNING** - This equipment has been tested and found to comply with the limits for a Class B digital device, pursuant to Part 15 of the FCC Rules and ICES-003 of Industry Canada. These limits are designed to provide reasonable protection against harmful interference when the equipment is operated in a commercial environment. This equipment generates, uses and can radiate radio frequency energy and, if not installed and used in accordance with the instruction manual, may cause harmful interference to radio communications. Operation of this equipment in a residential area is likely to cause harmful interference in which case the user will be required to correct the interference at his own expense. Intentional or unintentional changes or modifications not expressly approved by the party responsible for compliance shall not be made. Any such changes or modifications could void the user's authority to operate the equipment.

If necessary, the user should consult the dealer or an experienced radio/television technician for corrective action. The user may find the following booklet prepared by the Federal Communications Commission helpful: "How to Identify and Resolve Radio-TV Interference Problems." This booklet is available from the U.S. Government Printing Office, Washington, DC 20402, Stock No.004-000-00345-4.

## 1. UNPACKING

Unpack carefully. This is an electromechanical device and should be handled with care. Check to ensure that the following items are included:

- Integrated camera/housing unit
- Special Allen wrench
- IPIX Camera Manager (ICM) CD

## 2. SERVICE

If the unit needs repair service or parts, please contact IPIX customer service at 877-377-4749 for a return materials authorization and shipping instructions.

## 3. DESCRIPTION & SPECIFICATIONS

The CommandView™ Dome (CV-D2000) is a small, high performance, 2 mega-pixel network camera that provides ultra high quality video. The camera, combined with patented IPIX technology, enables users to digitally pan-tilt-zoom the 360° image with no moving parts and no blind spots.

The unit mounts easily to a single gang electrical box and can be wired through either the side or back of the housing via a standard 3/4 inch conduit opening. It is protected by a rugged, vandal resistant enclosure that uses an aluminum housing with a polycarbonate dome and is sealed for outdoor use.

**Construction/Finish:** Polycarbonate dome on cast aluminum housing with a powder coat.

**Power and Data Feeds:**

AC Voltage: 24VAC +/- 10%

DC Voltage: 12VDC +/- 10%

**Power Consumption:** 4 Watts Maximum

## 4. COVER REMOVAL & REPLACEMENT

1. Using the special Allen wrench provided, remove the 4 tamper resistant screws located on the cover assembly. The screws are captive and will remain with the cover. Refer to **Figure 1**.
2. Remove the cover assembly from the base to make the required camera adjustments.

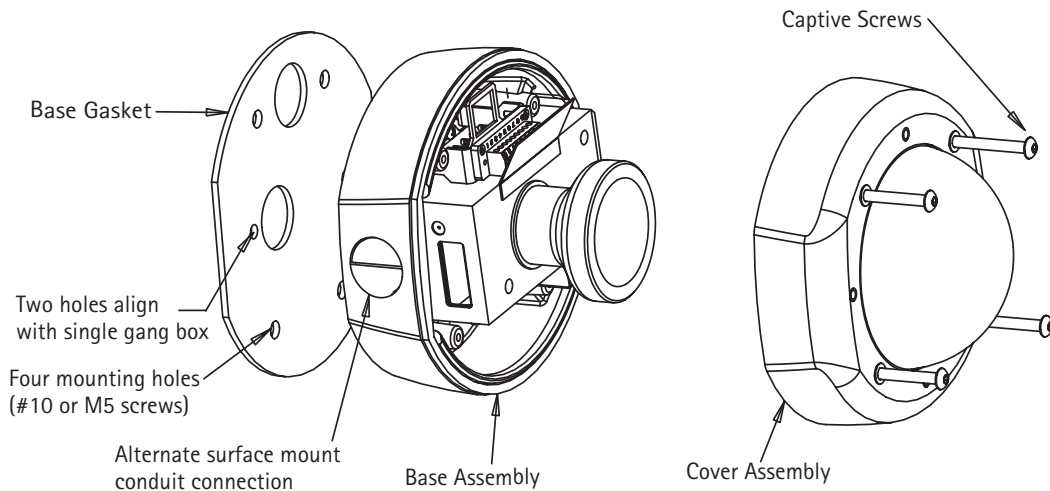

Figure 1 Dome Camera Assembly

## 5. INSTALLATION

**Attention:** Installations should be performed by qualified service personnel only in accordance with the National Electrical Code or applicable local codes.

### 5.1 Connecting Low Voltage Power & Network Communications

To mount to a single gang electrical box, run power and video lines through a knockout into the electrical box (not provided). For mounting directly to a wall or ceiling, run power and video lines to the desired location using 1-inch conduit.

**Caution:** Before proceeding, disconnect the power at its source and be sure that the unit is of the proper voltage type for the line power.

## 5.1.1 Connecting Low Voltage Power

The voltage supplied to the unit must be in the range of 21.6 to 26.4 VAC or 10.8 to 13.2 VDC. The unit is not polarity sensitive. Conductors should be sized accordingly for 4-watts of power consumption.

Leads are connected to the supplied terminal block according to the following wiring diagram (see Figure 2).

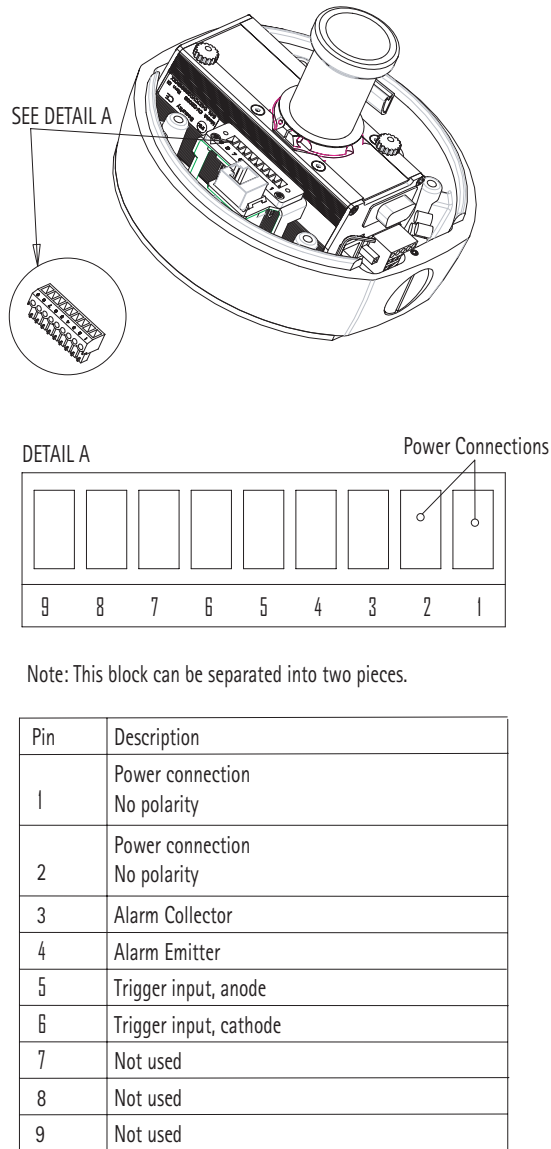

Figure 2 Power and Network Connections

## 5.1.2 Connecting Network Cable

Route and connect network cable to RJ45 connector.

## 5.2 Mounting

Refer to Figure 1.

1. Using the rubber base gasket as a template, mark the mounting hole locations on the mounting surface. The unit is intended to be mounted with four #10 screws or four MS screws (not supplied) through the four outer holes in the base casting.
2. Install the appropriate anchors or threaded inserts at the locations marked in Step 1.
3. Install a 3/4-inch threaded service conduit coupling into the back conduit hole, using pipe sealant on the threads. If conduit is to enter from the side, use a 2.5-mm or 3/32" Allen wrench to loosen the set screw from the conduit hole plug. Remove the plug and reinstall it in the conduit hole on the back of the unit.
4. If mounting this unit outdoors, apply a generous bead of silicone sealant around the back of the base casting and surround all holes. Apply the rubber base gasket to the back of the base casting and apply another generous bead of sealant to the outer edge around the exposed surface of the gasket.
5. Place the unit into position on the wall or ceiling. Install the mounting screws securely. If sealant is used, make sure that the sealant between the wall or ceiling and the gasket forms a complete seal. Add more sealant if needed. Make all final service connections and secure the conduit.

## 6. DESICCANT INSTALLATION

The desiccant packet supplied with the camera is used to minimize trapped moisture in the unit. The desiccant should be affixed to an inside surface of the camera in a manner that does not affect the view from the camera.

**Note:** Keep desiccant sealed in the plastic bag until the unit is ready for installation

## 7. CAMERA POST INSTALLATION

### 7.1 Indicator Lights

The camera has amber and green LEDs located on the bottom of the Ethernet connector. The amber light should be on for approximately 30 seconds after power has been applied to the camera. The camera is ready when the amber light turns off. The green LED indicates network connectivity. This light should be on or flashing. Absence of a green light indicates a problem with the Ethernet connection to the camera.

### 7.2 Configuring The IP Address

The camera ships from the factory with a default IP address of 192.168.1.222. The camera IP address and other camera parameters can be changed with the IPIX Camera Manager program on the supplied CD-ROM.

### 7.3 Focusing

The camera is focused at the factory. However, if the camera arrives out of focus, the following procedure should be used to adjust the focus:

1. Loosen the focus ring locking screws located on the side of the camera body.
2. Aim the camera at an area of detail while checking the image on the PC screen.
3. The camera must be stable while focusing. Turn the focus ring in the appropriate direction until the image is in focus.
4. Tighten the focus ring locking screws.

**Note:** It is important to use only the focus ring to focus the camera. The lens should remain stationary and tight in the focus ring.



Rev. 1



Rev. 2

## 7.4 Replace the Cover

Replace the cover and tighten the retaining screws securely.

## 8. DIMENSIONAL OUTLINE

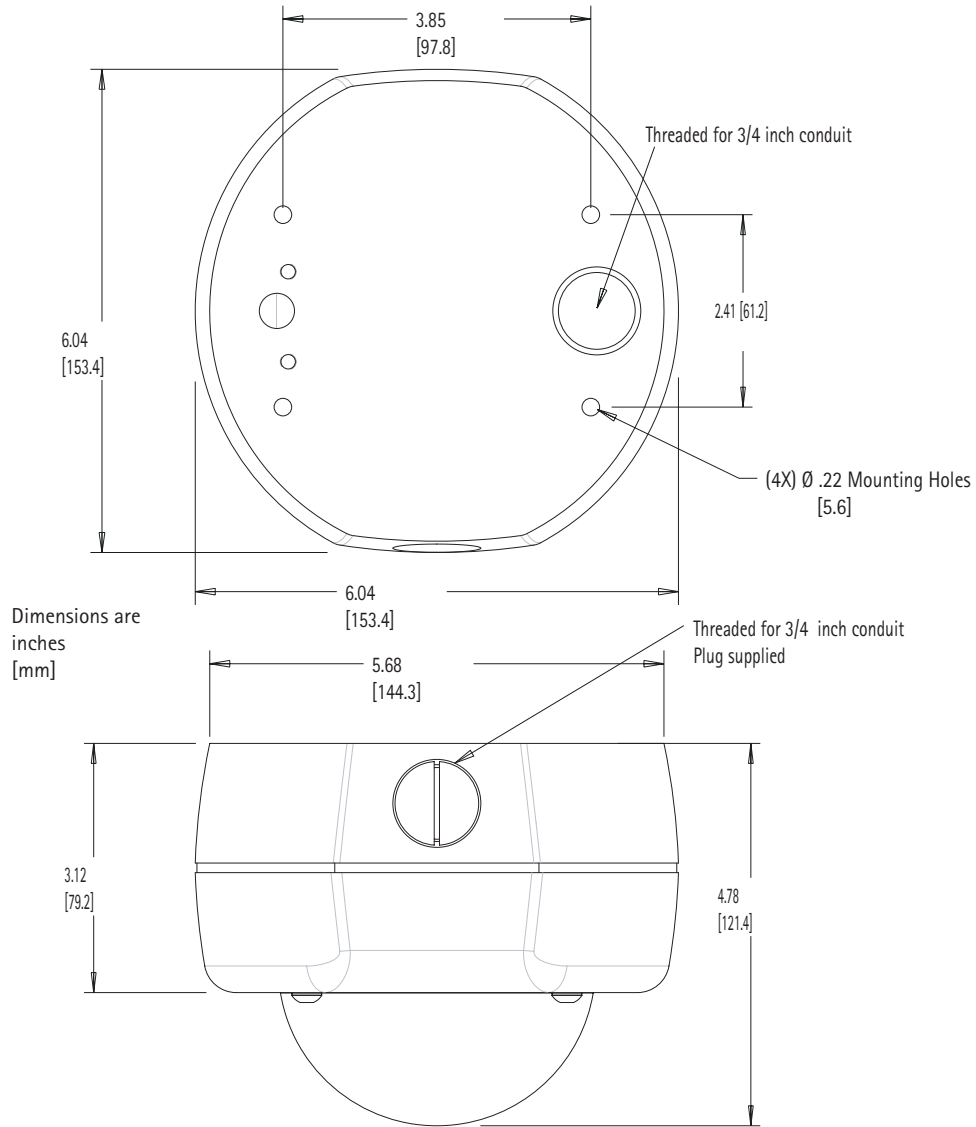

12120 Sunset Hills Road - Suite 410  
Reston, VA 20190  
Tel: 703-674-4100 Fax: 703-674-4101

IPIX, CommandView and InSight are trademarks or registered trademarks of IPIX Corporation  
Data subject to change without notice. IB:100 0104 005 IPX 10/05, printed in the U.S.A.